

Spec Sheet
4.04

Hek 500

DOL



www.selectplanthire.com

500 kg

1.4 m

TECHNICAL SPECIFICATIONS

TPL500

3Ph version

Payload capacity (kg)		500
Number of persons max (included on payload)	TP mode	5
Number of persons –	MH mode	0
Lifting speed (m/min)	TP Mode	12
Lifting speed (m/min)	MH mode	24
Platform dimensions [W x L]		1.4 x 1.6
Max Lifting height (tied)		100* m
Max Tie distance (m)		7.5
Max Overhang (m)		4.5
Max 1 st Tie Height (m)		6
Power supply		400 V -50 Hz. 3Ph
Rated Power (kW)		3.7 (TP)/4.4 (MH)
Rated current (A)		11
Power consumption (kVA)		7.5

Main dimension

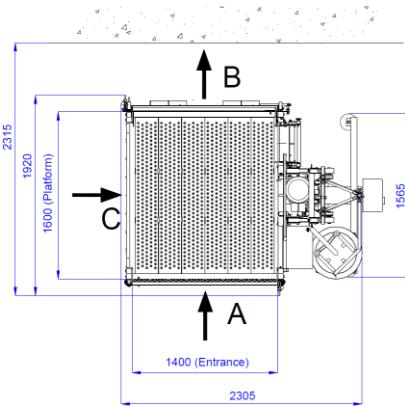

Weights (kg)

Base Unit	850
Mast	50
Tie In	42
Cable Guide	4

Entrance exit on A, B, C side
Exit on A and B side

